

**Separate**

*Selectable from  
Three Torch Types*



**TM Manipulators** That Support Both External & Through-Arm Torch Cable Routing

**Payload on Wrist Axis**

TL-1800: 8 kg

TL-2000: 6 kg



**TL Manipulators** with Long Arm & High Payload

# TM/TL Series GII

Combination with Full Digital Welding Power Source Achieves Stable and High Quality Welding

## Torch type selectable to fit your application!

TM series



Separate Type



Through-Arm Type



External Type

TM
1100
1400
1600
1800
2000

## Long-arm & high payload!

TL series



External Type

TL
1800
2000

Payload  
TL-1800: **8 kg**  
TL-2000: **6 kg**

### Manipulator Lineup (as of September 2016)

	TM series					TL series	
	1100	1400	1600	1800	2000	1800	2000
Separate	○	○	○	○	○	—	—
Through-Arm	○	○	○	○	○	—	—
External	○	○	—	—	—	○	○
Payload	6 kg		4 kg	6 kg		8 kg	6 kg

## A variety of features specialized for arc welding

### Feature 1 (TM/TL) Enhanced Basic Performance

#### Increased Motion Speed

TM-1400: Speed of main 3 axes increased by 22 % on average. (approx. 42°/s more than TA type)

#### Extended Reach

TM-1400: 1 437 mm (63 mm more than TA type)

### Feature 2 (TM) Arm Specialized for Welding

**Cantilever Structure** makes arm compact and improves accessibility to workpieces.

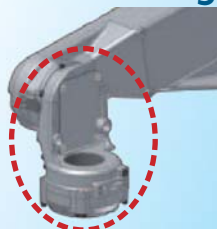

### Feature 3 (TM/TL) Structure Specialized for Welding Clean Cable Management!

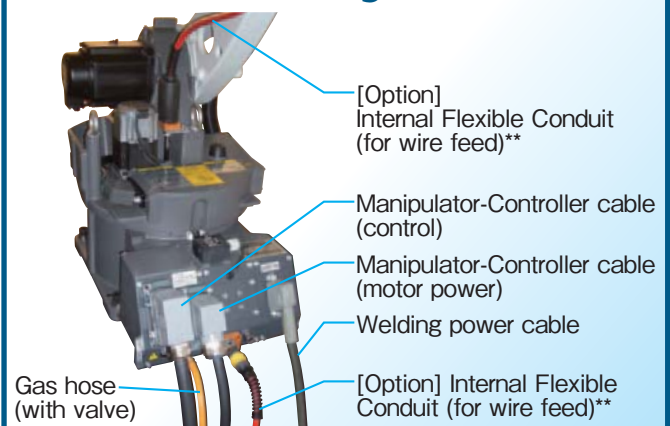

\*\*For use with drum packing wire only.

# TM Series GII

Selectable from Three Torch Types.  
Focused on Wire Feedability and  
Reduced Cable Interference.

In addition to Through-Arm Type and External Type,

## A third choice—Separate Type

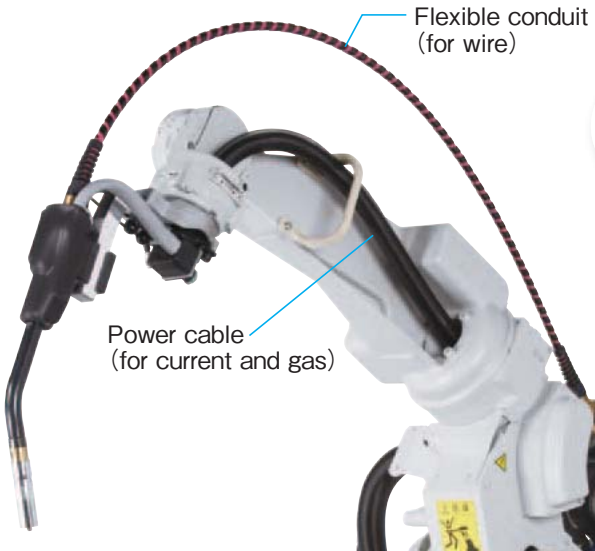

**High Wire Feedability  
Less Cable Interference**

TM
1100
1400
1600
1800
2000

## Separate Type—

Revolutionary new type of arc welding robot with advantages of both Through-Arm Type and External Type.

### Feature 1 External Flexible Conduit

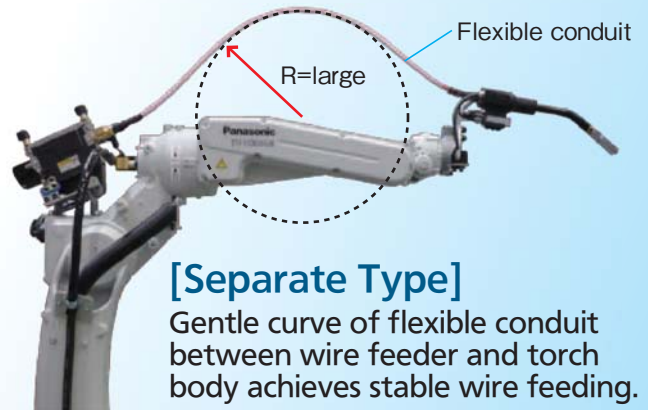
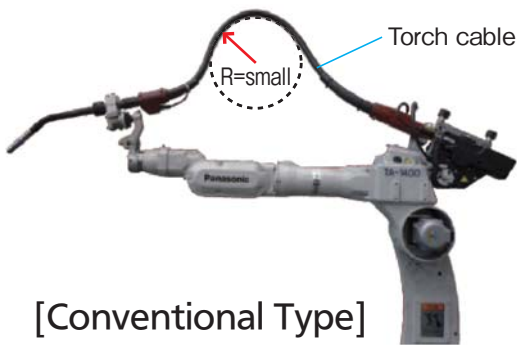

### Feature 2 Through-Arm Power Cable

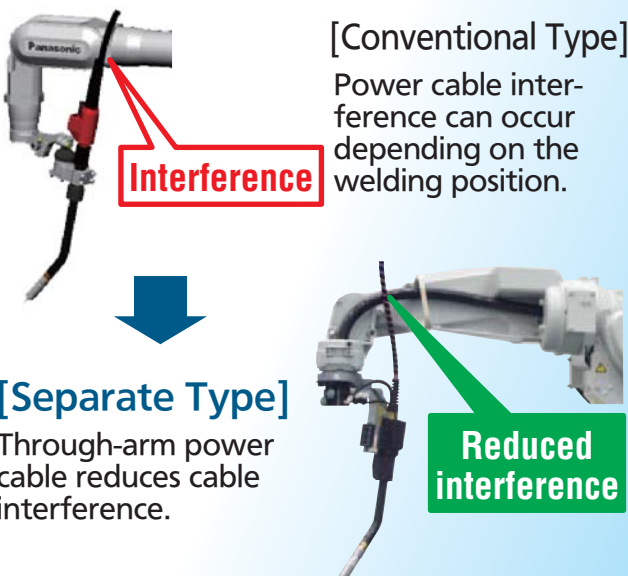

### An example of circumferential welding



New type welding robot achieves even higher quality welds.

### GIII controller with high performance

- Faster CPU reduces start-up time to **about 30 seconds.** (50 % reduction from previous model)
- Optional memory allows storing 800,000 teaching points in addition to the standard 40,000 points.



### Teach pendant with enhanced operability

Operating function key



User function key

Same basic operation procedure with G2 Series model  
Easy to use Windows based operation

- Light weight design under 1 kg (0.99 kg) giving you less stress during teaching
- Liquid crystal LED back light improving impact resistance
- USB and SD memory interface realizing great expandability
- Increased number of function keys (four to eight), enabling same action with less key strokes during teaching

### Improved maintainability

- Swivel rack in the case makes maintenance easy and saves space.
- Cables with connectors on both ends reduce Cable exchange time.

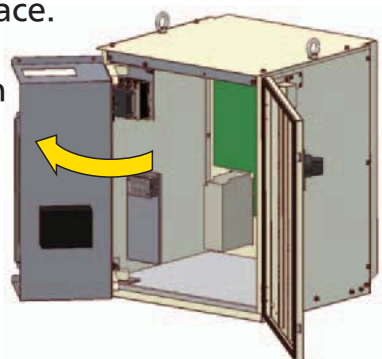

Swivel rack

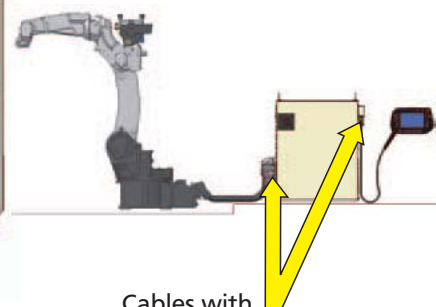

Cables with connector on both ends

# Standard Features

## Weaving Function (6 patterns)

You just have to teach the starting point, amplitudes, turning points and ending point. Teaching time will be reduced.

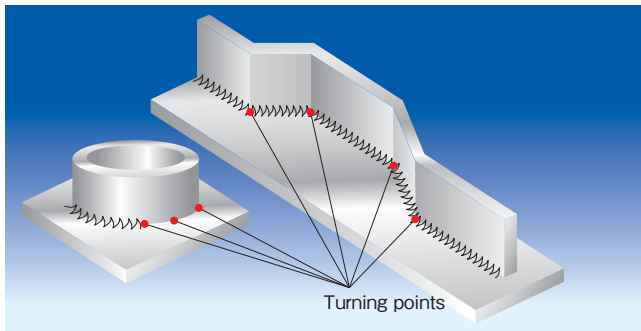

## Parallel Shift + RT Axis Rotating

Teaching time of same workpieces is reduced.

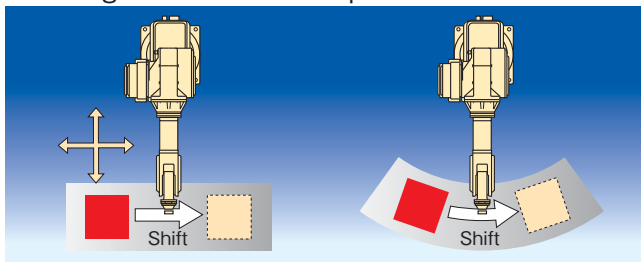

## Torch Angle Display (Teach Pendant)



Torch angle is displayed on the screen, making it possible to reduce teaching time and obtain consistent bead appearance.

## Overlap Function (CO<sub>2</sub>/MAG welding)

In case of interruption during welding, the torch is stepped back by reboot and resumes the welding from the welding end point.

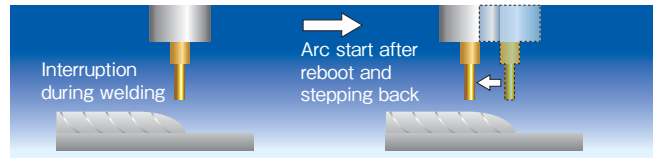

## Arc Start Retry (CO<sub>2</sub>/MAG welding)

Detecting a failure of arc start, the robot automatically starts arc ignition again.

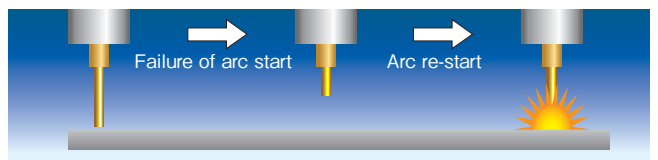

# Optional Features

## "Weld Navigation" allows easy parameter setting

Easy setting with Teach Pendant



Note: Screens are subject to change without notice.

Rich welding parameter database developed through our long experience

"Weld Navigation" reduces parameter setting time.

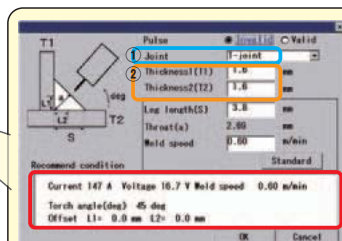

Note: Torch angle and aiming point also calculated

### Two Easy Steps:

1. Select weld joint. The figure changes according to the joint.



2. Select plate thicknesses. That's all!

### The right parameters automatically

Leg length and weld speed are also adjustable.

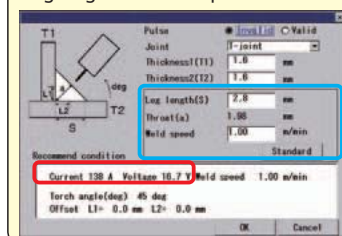

Notes: Parameters by Weld Navigation are guideline only and do not guarantee welding result. Consult us for material and processes available with Weld Navigation.

Weld Navigation recalculates weld current and voltage according to the changes.



Model: 350GZ4

## Arc Sensor

The sensor corrects deviation from the taught weld line by detecting weld current changes during weaving welding.

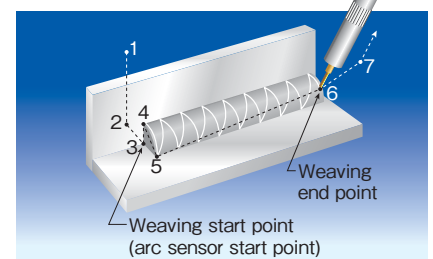

## Touch Sensor

The welding wire touches the workpiece and compensates a workpiece position error, which reduces jig costs.

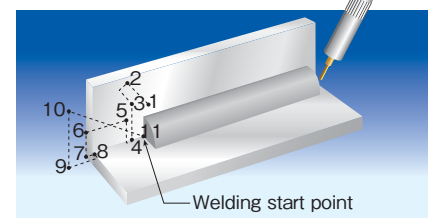

## Expansion

### Multi-Mechanism Control

Controls maximum 6 groups of robots and external axes in parallel.

### Cooperative Multi-Robot Control

Allows cooperative control between two robots.

## Units

- Analog I/O Expansion Unit
- Relay Connection Unit
- Terminal Block Conversion Unit
- External Power Input Unit

# CO<sub>2</sub>/MAG/MIG Robot System (GIII)

Combination with Full Digital Welding Power Source Achieves Stable and High Quality Welding

CO<sub>2</sub>/MAG/MIG welding robot system selectable to fit your application

Full Digital CO<sub>2</sub>/MAG welding machines GZ4 series

## SP-MAG

(Super-imposition Control)

TM	TL
1100	1800
1400	2000
1600	
1800	
2000	



Equipped with TAWERS's SP Control Praised by Many of Our Customers

### SP-MAG benefits:

- Reduced spatter (Reduced removal work)
- Shorter short-circuit cycle suited for high speed welding
- Shorter arc length for good bead appearance



TM-1400GIII (Separate)

## Good bead appearance and low spatter even in high speed welding

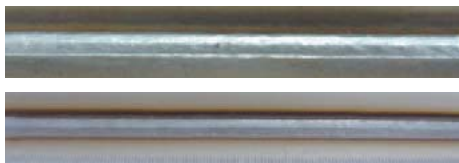

### MAG welding (220 A)

- Joint: Fillet • Base metal: Mild steel SPCC (t2.3 mm) • Weld current: 220 A
- Weld speed: 100 cm/min • Wire size: 1.2 mm (YM-50MT)
- Shielding gas: MAG (80 % Ar + 20 % CO<sub>2</sub>)

### MIG welding (180 A)

- Joint: Fillet • Base metal: SUS308(t1.5 mm) • Weld current: 180 A
- Weld speed: 80 cm/min • Wire size: 1.2 mm (Y308Lsi)
- Shielding gas: MIG (98 % Ar + 2 % O<sub>2</sub>)

Note: Optional parts are necessary to connect GZ4 to robot.

### Spatter generation

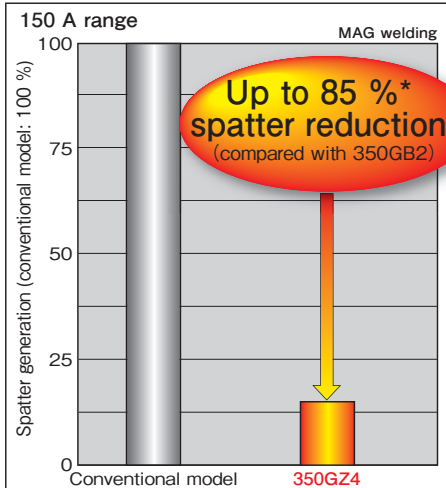

\*UP to 80% spatter reduction from 500GB2 to 500GZ4 in 250 A range

### Conventional model



### Conventional model (150 A)



### 350GZ4



### 350GZ4 (150 A)



- Joint: Fillet • Base metal: Mild steel SPCC (t2.3 mm) • Weld current: 150 A
- Weld speed: 50 cm/min • Wire size: 1.2 mm (YM-50MT)
- Shielding gas: MAG (80 % Ar + 20 % CO<sub>2</sub>)

### Full Digital Controlled Welding Machine

# FULL DIGITAL

CO<sub>2</sub>/MAG/MIG  
Welding Machine  
Lineup for  
High Quality Welds



# Medium/Thick Plate Welding Robot System (GIII)

## Optional Functions Effective for Medium and Thick Plates

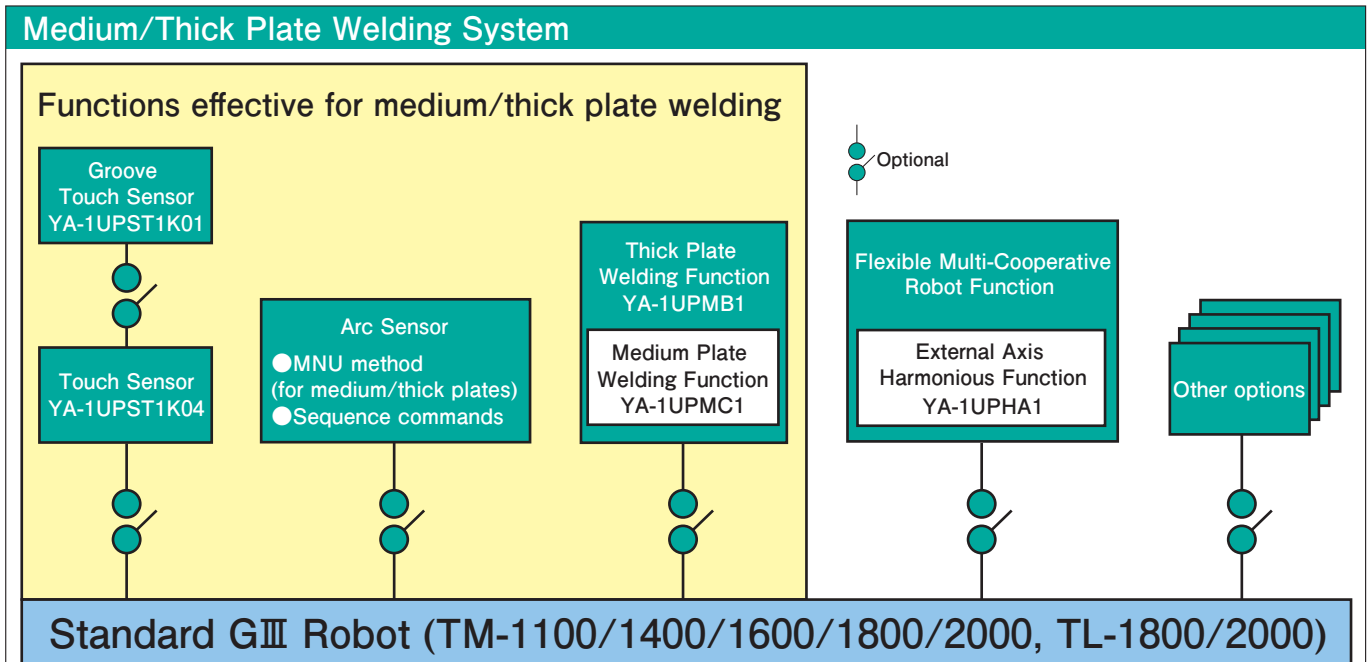

Consult us for details.

### Examples

#### How Touch Sensor works

Touches base metal and determines line to be welded.

Detects positioning error and determines line to be welded again.

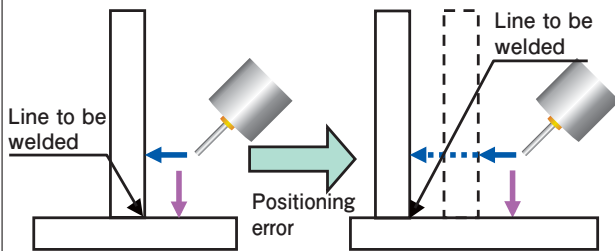

#### How Arc Sensor works

Detects misalignment or distortion and compensates it.

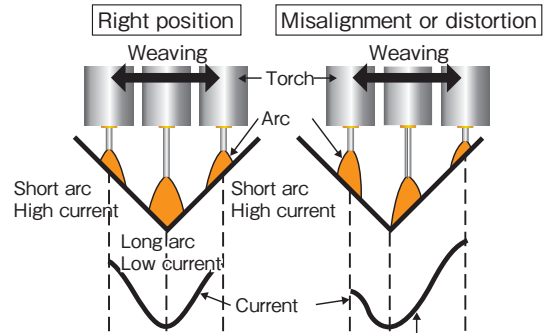

A deviation of weaving center from joint center changes balance of current changes.

#### Groove Touch Sensor Function

Senses groove width and center, and compensates misalignment.

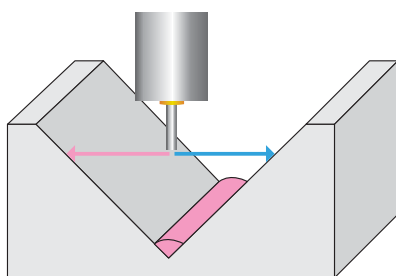

#### Variable Weaving Function Thick Plate Welding Function (YA-1UPMB1)

Supports changes of groove width. Controls deposited metal amount and maintains uniform bead height.

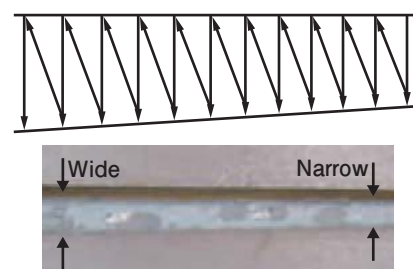

# TIG Robot System (GIII)

High Quality Welding  
in Combination with  
Full Digital Welding Power Source

Robotic TIG welding system selectable to fit your application

## Model Selection Guide

Type	Material	Filler wire dia. (mm)	Welding power source	Robot
Autogenous TIG (no filler)	Stainless steel	—	300BZ3	TM-1100 TM-1400
	Stainless steel Aluminum	—	300BP4 500BP4	TL-1800
Filler TIG	Stainless steel	(0.9)/1.2/(1.6)	300BZ3	TM-1100 TM-1400
	Stainless steel Aluminum	(0.9)/1.2/(1.6)	300BP4 500BP4	TL-1800
Rotary filler TIG	Stainless steel	(0.9)/1.2/(1.6)	300BZ3	TL-1800
	Stainless steel Aluminum	(0.9)/1.2/(1.6)	300BP4 500BP4	

Notes:

- An external axis controller is necessary for rotary filler TIG welding.
- Diameters in ( ) are available with optional parts.



Rotary filler TIG Welding Robot System  
TL-1800GIII

## Features of Rotary TIG Filler Unit

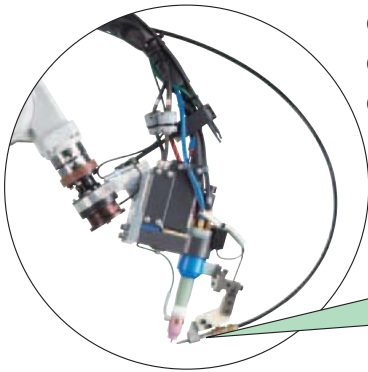

- Optimum welding position
- High precision filler wire feed
- Improved workpiece accessibility

Filler wire tip position is adjustable in all directions.

## TIG welding torch lineup



YT-TCT201  
• Air-cooled  
• 35 % duty cycle at 200 A



YT-TCT401  
• Water-cooled  
• 60 % duty cycle at 400 A

## Full Digital Controlled Welding Machine

# FULL DIGITAL

## TIG Welding Machine Lineup That Offers High Quality Welding

### AC/DC TIG welding machine



300BP4



500BP4

### DC TIG welding machine



300BZ3



# Dimensions & Work Envelope

(Unit: mm)

## Short Type TM-1100

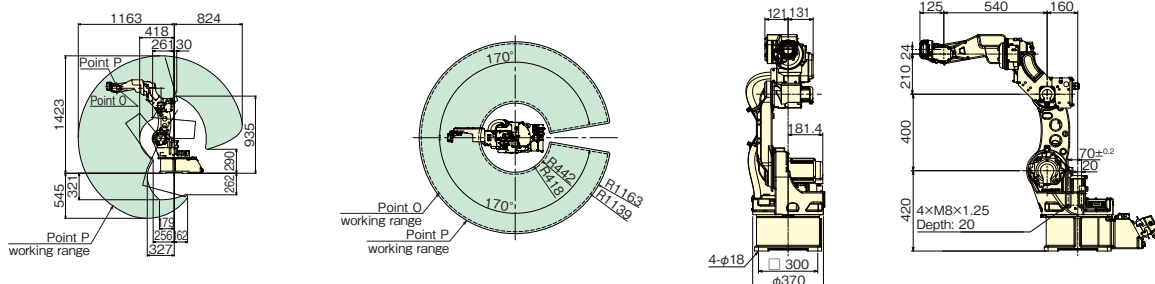

## Standard Type TM-1400

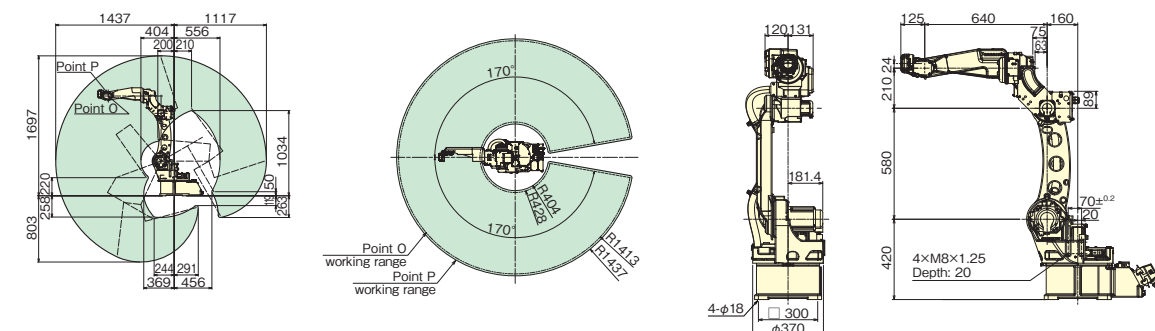

## Middle Type TM-1600

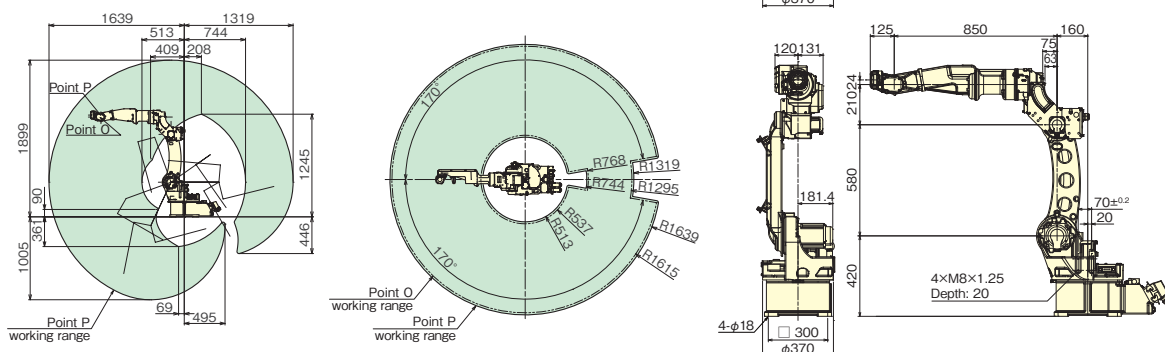

## Long Type TM-1800

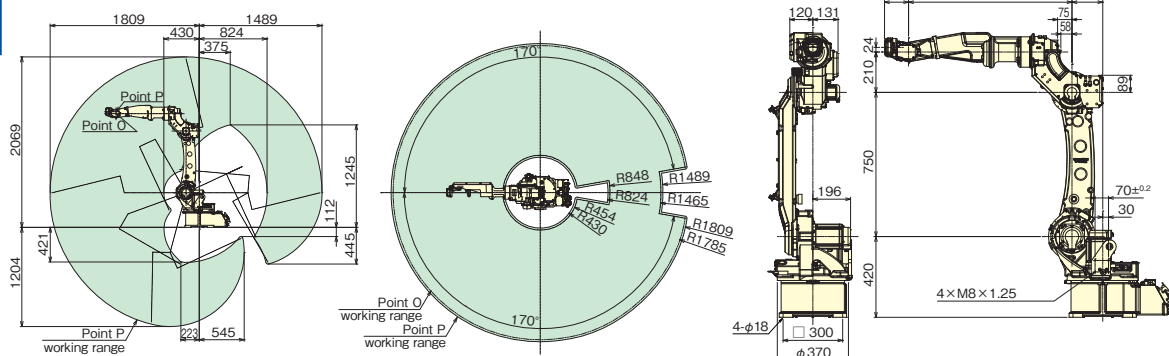

### Manipulator General Specifications

Model	TM-1100	TM-1400	TM-1600	TM-1800	TM-2000	TL-1800	TL-2000
Type	Short arm	Standard arm	Middle arm	Long arm	Long arm	Long arm	Long arm
Structure	6 axis articulated						
Payload	6 kg		4 kg	6 kg		8 kg	6 kg
Maximum Reach	1 163 mm	1 437 mm	1 639 mm	1 809 mm	2 011 mm	1 801 mm	1 999 mm
Minimum Reach	418 mm	404 mm	513 mm	430 mm	550 mm	383 mm	491 mm
Working Range	745 mm	1 033 mm	1 126 mm	1 379 mm	1 461 mm	1 418 mm	1 508 mm
Max. Motion Speed	RT (Rotating trunk)	225°/s		210°/s	195°/s		195°/s
	UA (Upper arm)	225°/s		210°/s	197°/s		197°/s
	FA (Forearm)	225°/s		215°/s	205°/s		205°/s
	RW (Rotating wrist)	425°/s		425°/s	425°/s		385°/s
	BW (Bending wrist)	425°/s		425°/s	425°/s		375°/s
TW (Twisting wrist)	629°/s		629°/s	629°/s		624°/s	
Position Repeatability	±0.08 mm				±0.10 mm	±0.08 mm	±0.15 mm
Motors	Total Power	3 400 W		4 700 W		5 050 W	
	Brakes	All axes					
Mounting	Floor / Ceiling*						
Weight	156 kg	170 kg	180 kg	215 kg	217 kg	215 kg	216 kg

\*Ceiling mount type is factory optional.

# Dimensions & Work Envelope

(Unit: mm)

## Long Type TM-2000

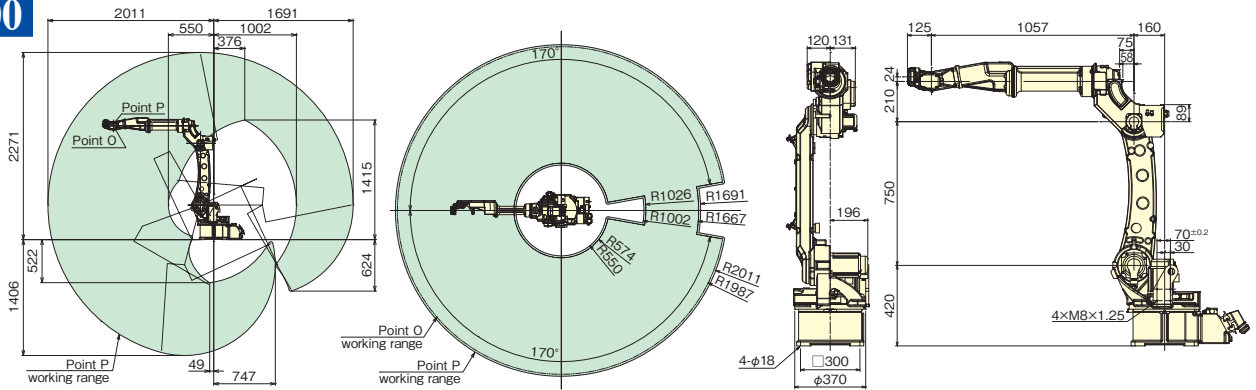

## Long Type TL-1800

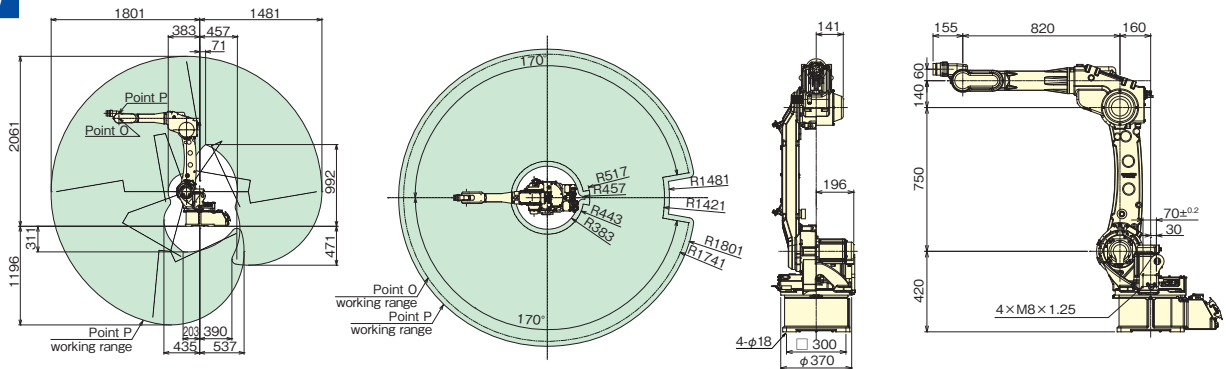

## Long Type TL-2000

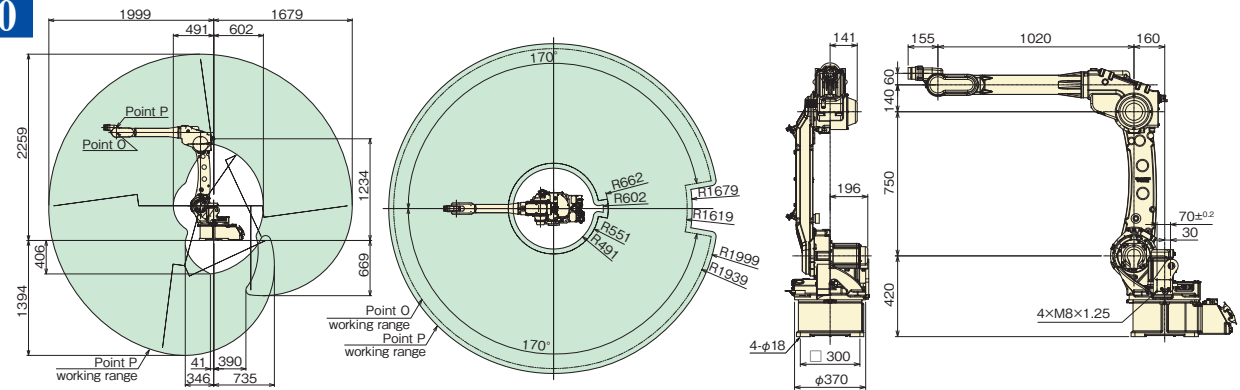

## Controller Specifications

### Controller

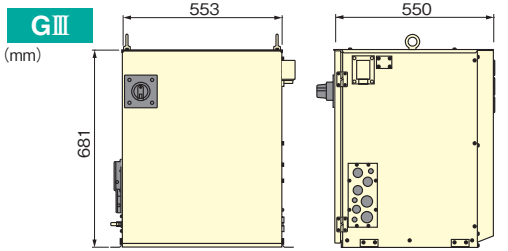

Model	GIII
Dimensions*1	W 553 mm x D 550 mm x H 681 mm
Weight*2	60 kg
Memory Capacity	40 000 points
Position Control	Software servo control
External Memory	Teach Pendant: one SD memory card slot, Two USB 2.0 ports (USB 2.0 Hi-Speed not supported)
Control Axes	6 axes simultaneously (Max.27 axes)
Input and Output	Input: 40 points (Optionally expandable up to 2048 points) Output: 40 points (Optionally expandable up to 2048 points)
Input Power	3 phase, 200/220 VAC±20 V, 3 kVA, 50/60 Hz

\*1: Protruding portions not included.

\*2: Teach pendant and connection cables not included.

### Teach pendant

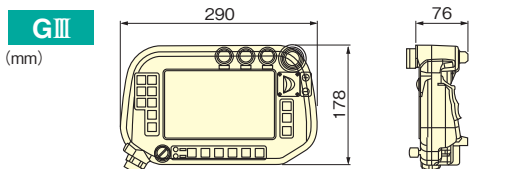

# Large Robot Series (GIII Controller)

**Great material handling capability!  
Coordinated multi-robot movement  
for flexible system without jig.**

- Coordinated movement with WGIII/GIII robot(s)



Allows to build flexible system without jig.

Maximum configuration:  
• Arc welding robot x 2  
• Large robot x 1

- GIII controller for large robots

Same operation, maintenance and options as conventional robots



YS-080GIII



HS-220GIII

## Manipulator General Specifications

Model	YS-080GIII	HS-220GIII		
Type	6 axis articulated robot			
Payload	80 kg	220 kg		
Working Range	RT (Rotating trunk)	±180°	±178°	
	UA (Upper arm)	-80° ~ +155°	-65° ~ +80°	
	FA (Forearm)	Referenced from Horizontal	-140° ~ +230°	-130° ~ +230°
		Referenced from upper arm	-80° ~ +180°	-73° ~ +190°
	RW (Rotating wrist)	±360°	±360°	
	BW (Bending wrist)	±125°	±128°	
Max. Motion Speed	TW (Twisting wrist)	±360°	±360°	
	RT (Rotating trunk)	170°/s	120°/s	
	UA (Upper arm)	140°/s	105°/s	
	FA (Forearm)	160°/s	110°/s	
	RW (Rotating wrist)	230°/s	145°/s	
Weight	BW (Bending wrist)	230°/s	145°/s	
	TW (Twisting wrist)	350°/s	220°/s	
	645 kg	955 kg		

## Tilt-Rotate Positioners High-Speed Type R Series



Two types available: 300 kg and 500 kg payload

- 1.8 times faster maximum speed compared with the conventional models.
- Smallest-in-class footprint of 780 × 500 mm. (300 kg payload model)
- Easier installation with three selectable cable outlet positions.

## Specifications

Name	Positioner unit		
Model	YA-1RJC62	YA-1RJC72	
Applicable Robot	Panasonic robots TM/TL series with GIII/WGIII controller		
Payload	300 kg	500 kg	
Max. Speed	Rotation	190.0°/s (31 r/min)	165.0°/s (27 r/min)
	Tilt	125.5°/s (20 r/min)	90.0°/s (15 r/min)
Operating Range	Rotation	-3 600° to +3 600° (with multi-rotation data reset function)	
	Tilt	-135° to +135°	
Allowable Moment	Rotation	323 N·m	392 N·m
	Tilt	882 N·m	1 274 N·m
Position Repeatability	±0.05 mm (R=250 mm)		
Hollow Shaft Diameter	55 mm		
Allowable Welding Current	500 A @ 60 % duty cycle		
Weight	285 kg		
Applicable Welding Process	CO <sub>2</sub> /MAG/MIG/TIG		
External Axis Controller Type	Internal/External		

## Single-axis positioners

Payload: 250/500 kg

Payload: 1000 kg



RJB 12/22



RJB 32

## Side mount 2-axis positioners

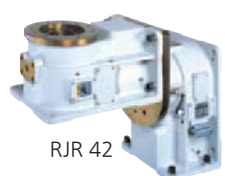

RJR 42



RJR 52

## Specifications

Name	Positioner unit		
Model	YA-1RJB12	YA-1RJB22	YA-1RJB32
Applicable Robot	Panasonic robots TM/TL series with GIII/WGIII controller		
Payload	250 kg	500 kg	1 000 kg
Max. Rotational Speed	190°/s (31.6 r/min)	120°/s (20 r/min)	120°/s (20 r/min)
Operating Range	-3 600° to +3 600° (with multi-rotation data reset function)		
Allowable Torque	196 N·m	490 N·m	1 470 N·m
Allowable Moment	1 470 N·m	1 470 N·m	6 125 N·m
Position Repeatability	±0.05 mm (R=250)		
Hollow Shaft Diameter	55 mm	55 mm	75 mm
Brakes	Provided		
Allowable Welding Current	500 A @ 60 % duty cycle		
Weight	125 kg	255 kg	
Applicable Welding Process	CO <sub>2</sub> /MAG/MIG/TIG		
External Axis Controller Type	Internal/External	External	

# FA Technical Centers

Feel the excellent performance of TAWERS

FATC (Tangshan)



FATC (Shanghai)



FATC (Guangzhou)



FATC (Jhajar)



FATC (Pune)



FATC (Bangkok)



FATC (Dusseldorf)



**Process Development**

**Process verification prior to system installation.**

Case Examples:

- New factory weld processing
- Improvement of existing processes
- Develop new welding solutions



**Consulting**



**Welding and Robot College**

**We support development of highly skilled welding operators.**

Workshops:

- Robot
- MAG/MIG
- TIG
- Special training

**Professional staff offer technical solutions.**

Qualifications:

- Welding coordination personnels (including first class)
- JIS qualified welding operators
- Metal materials inspectors
- International welding license holders



**We provide products that are friendly to the environment.**

As an earth-friendly company, Panasonic Corporation discourages the use of hazardous substances in our products. The products of Panasonic Corporation comply with the European RoHS directive.



## Safety precautions

- Before attempting to use any welding product always read the manual to ensure correct use.

### Panasonic Corporation

Smart Factory Solutions Business Division, Business Innovation Center  
1-1, 3-chome, Inazu-cho, Toyonaka, OSAKA 561-0854 **Japan**  
TEL: 81-6-6866-8505 FAX: 81-6-6866-0709

### Panasonic Welding Systems Co., Ltd.

<http://www.panasonic.com/jp/company/pws/en.html>

### Panasonic Welding Systems (Tangshan) Co., Ltd.

No.9 Qingnan Rd., Tangshan New & Hi-Tech Industrial Park,  
063020 Hebei, **China**  
TEL: 86-315-320-6060 FAX: 86-315-320-6070  
<http://pwst.panasonic.cn>

### Panasonic Welding Systems India

Industrial Plot No.1, Village Bid Dadri, Jhajar - 124103,  
Haryana, **India**

### Panasonic Factory Solutions Company of America

1701 Golf Road, Suite 3-1200 Rolling Meadows, IL 60008 **USA**  
TEL: 1-847-637-9700 FAX: 1-847-637-9601  
<http://www.panasonicfa.com>

### Panasonic Automotive & Industrial Systems Europe GmbH

Jagenbergstr 11a, D-41468 Neuss **Germany**  
TEL: 49-2131-60899-0 FAX: 49-2131-60899-200  
<http://eu.industrial.panasonic.com/>

### Panasonic Industrial Devices Sales (Thailand) Co., Ltd.

252/133 Muang Thai-Phatra Complex Building, 31st Fl.  
Rachadaphisek Rd., Huaykwang, Bangkok 10320 **Thailand**  
TEL: 662-693-3421 FAX: 662-693-3427

● Specifications are subject to change without notice.

● Windows is a registered trademark of Microsoft Corporation in the United States and other countries.

Catalog No. **IRTMTL-GIII**

Printed in Japan [2016.9] 3-004U